

Hydraulic Sloan® 9603 Prison Model Flushometer

► Description

Concealed Hydraulically Activated Water Closet Flushometer, for Stainless Steel back spud water closets and Combination Fixtures. For use with: Acorn® • Bradley® • Metcraft® • Willoughby® and similar fixtures.

► Flush Cycle

- Model 9603 Water Saver (3.5 gpf/13.2 Lpf)
- Model 9603-1.6 Low Consumption (1.6 gpf/6.0 Lpf)

► Specifications

Quiet, Concealed, Diaphragm Type, Rough Brass Closet Flushometer for either left or right hand supply with the following features:

- High Chloramine Resistant PERMEX™ Synthetic Rubber Diaphragm with Linear Filtered Bypass and Vortex Cleansing Action™
- ADA Compliant Non-Hold-Open feature type Actuator (specify Actuator type listed below)
- 1" I.P.S. Wheel Handle Bak-Chek® Angle Stop
- Adjustable Tailpiece
- High Back Pressure Vacuum Breaker
- Elbow Flush Connection and Coupling for 1-1/2" NPT Back Inlet (for connection in the pipe chase — flush connection through the wall not provided by Sloan)
- Exposed parts Chrome Plated
- High Copper, Low Zinc Brass Castings for Dezincification Resistance
- Non-Hold-Open Push Button, Fixed Metering Bypass and No External Volume Adjustment to Ensure Water Conservation
- Low Consumption Flush Accuracy
- Handle Packing, Stop Seat and Vacuum Breaker molded from PERMEX™ Rubber Compound for Chloramine Resistance
- 100% of the energy used in manufacturing is offset with Renewable Energy Sources – Wind Energy

Valve Body, Cover, Tailpiece and Control Stop shall be in conformance with ASTM Alloy Classification for Semi-Red Brass. Valve shall be in compliance to the applicable sections of ASSE 1037.

► Actuator Types: (please check one)

- MBFW** Metal Button Fixture Wall Actuator (HY-100-A) (rear access)
- MBPM** Metal Button Panel Mount (HY-108-A) for use only with Wall Box or when Access Panel is provided in combination fixture

► Variations

- AFD** Shorter Vacuum Breaker - for use with Anti-Flood Device (Anti-Flood Device NOT provided by Sloan)
- DFB** Dual Filtered Fixed Bypass Diaphragm
- YB** Sweat Solder Adapter

Water Closet

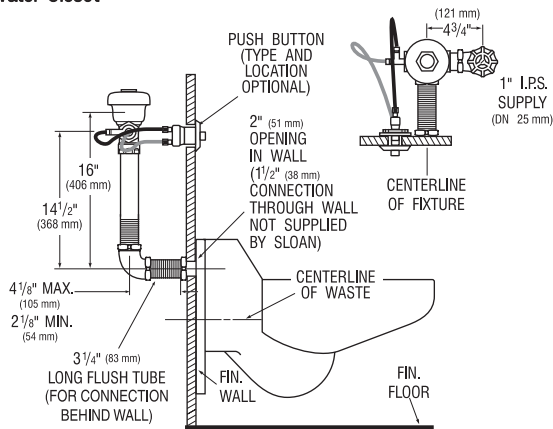

Combination Fixture

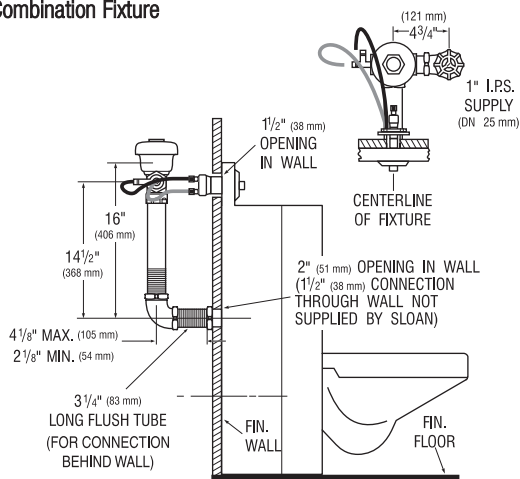

Sloan Prison 9603 S.S. — Rev. 0c (11/10)
Copyright © 2010 SLOAN VALVE COMPANY



This space for Architect/Engineer approval

Job Name _____ Date _____

Model Specified _____ Quantity _____

Variations Specified _____

Customer/Wholesaler _____

Contractor _____

Architect _____

The information contained in this document is subject to change without notice.



Made in the U.S.A.
SLOAN VALVE COMPANY • 10500 SEYMOUR AVE. • FRANKLIN PARK, IL. 60131
Ph: 1-800-9-VALVE-9 or 1-847-671-4300 • Fax: 1-800-447-8329 or 1-847-671-4380
www.sloanvalve.com